

Introduction

Migdal Effect

- Sudden movement of nucleus causes an ionization or excitation.
- Induced by nuclear recoil, enhancing sensitivity to light dark matter (WIMPs).
 - Nuclear recoil + additional energy loss
- We aim to observe the Migdal effect in noble gas nucleus (Argon and Xenon) which is widely used as a target for direct WIMP searches.

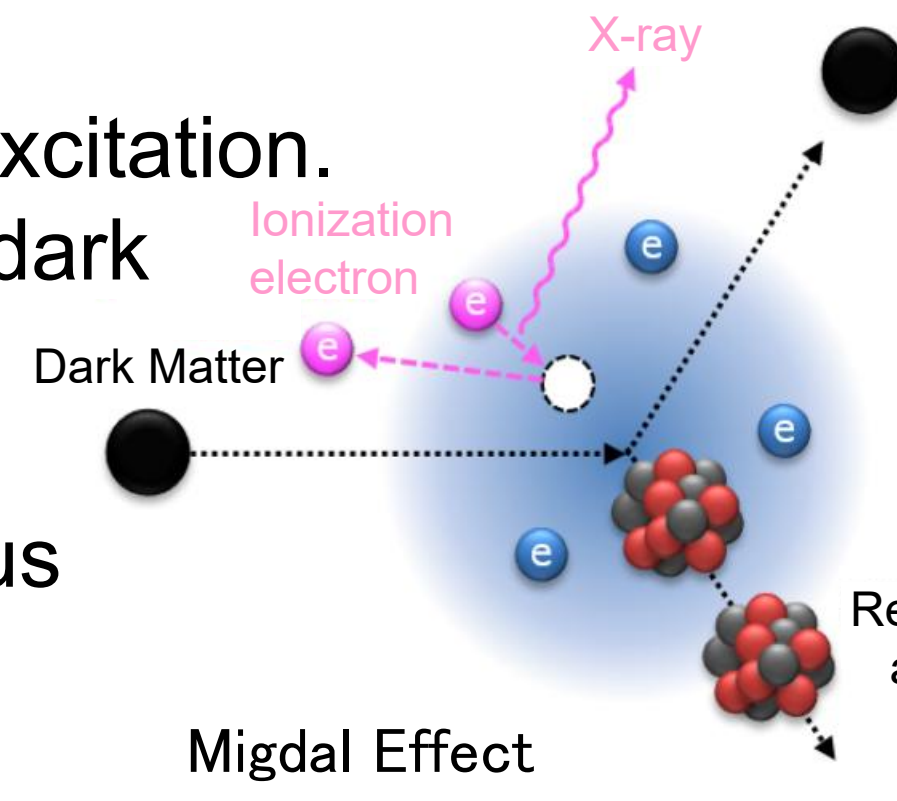

MIRACLUE Experiment

- Migdal effect search using a neutron beams
- Detection of nuclear recoil + characteristic X-rays
 - Two-cluster reconstruction is required.
- Detector : Gaseous TPC
 - Tohoku Univ. : high-pressure Xenon
 - Kobe Univ. : Argon

Xe : K. Nakamura (Talk)
A. Nakano (Poster)
Ar : K. Suzuki (Talk)

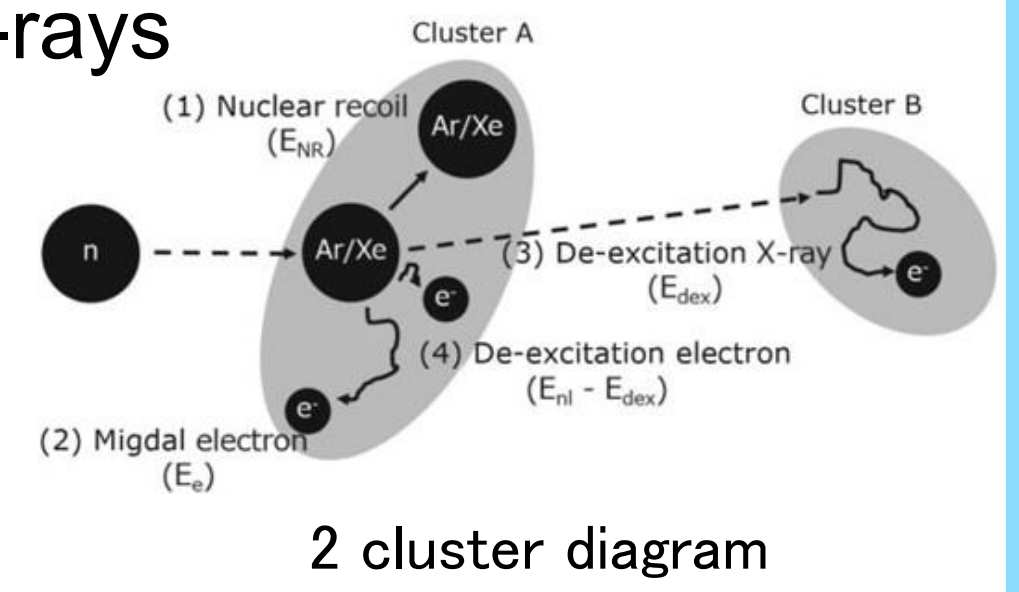

Detector and Readout System

Argon Gaseous TPC

- Detection principle
 - Ionized electrons drift along the electric field.
 - Charge is amplified and read out in two dimensions by GEM + μ -PIC.
 - Data are acquired with readout boards.

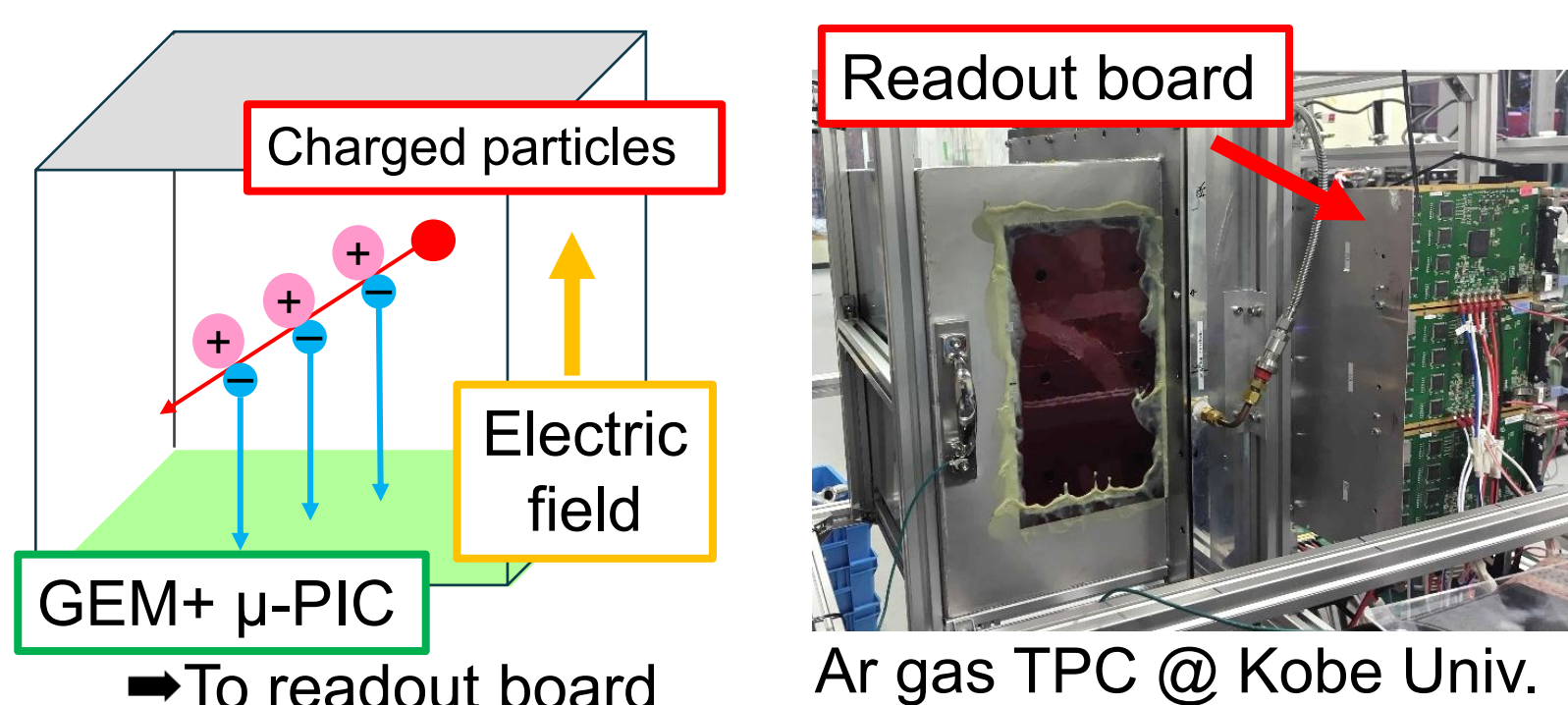

- μ -PIC
 - 400 μ m pitch, 30 cm square
 - 768-channel anode and 768-channel cathode
- 3D track reconstruction
 - 2D position + timing

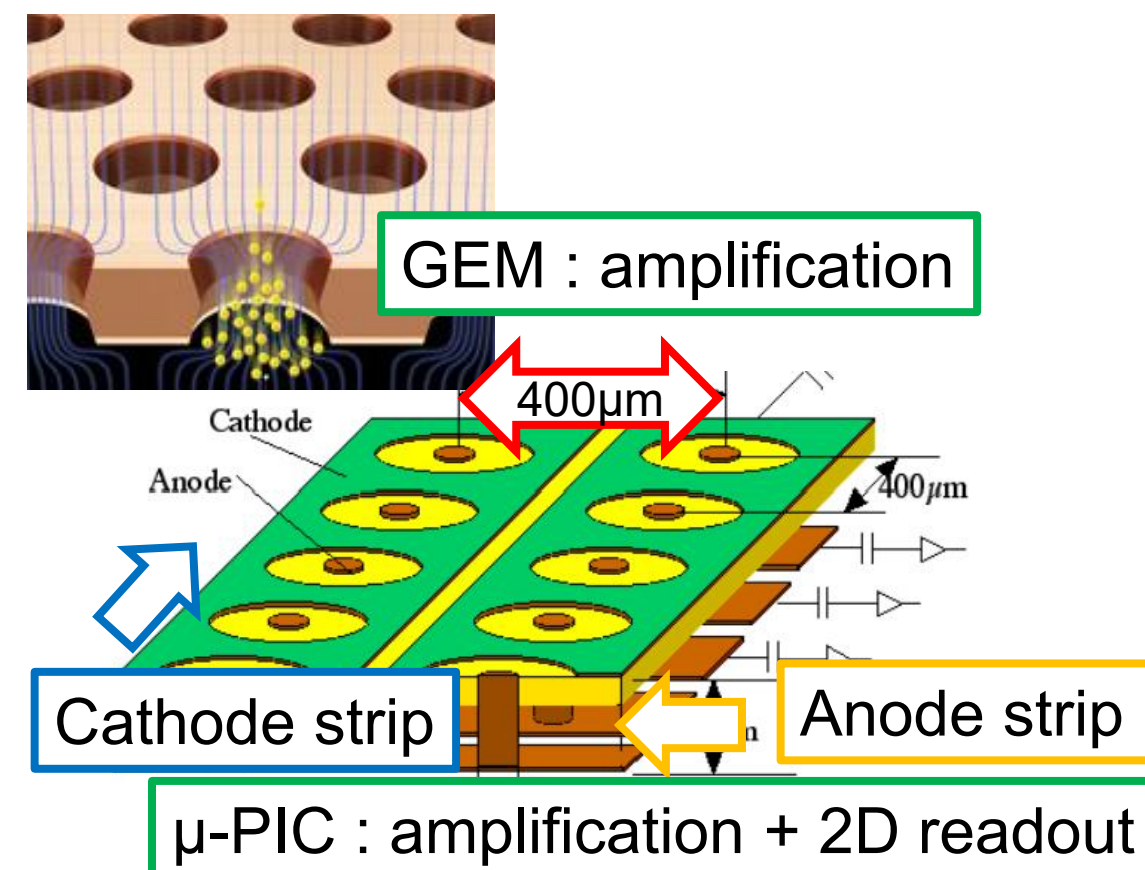

Readout System

- Readout board
 - Input
 - 128-ch signals from μ -TPC
 - Output
 - 128-ch time over threshold / 128-ch time of flight
 - 4-ch waveform (32ch bundled)

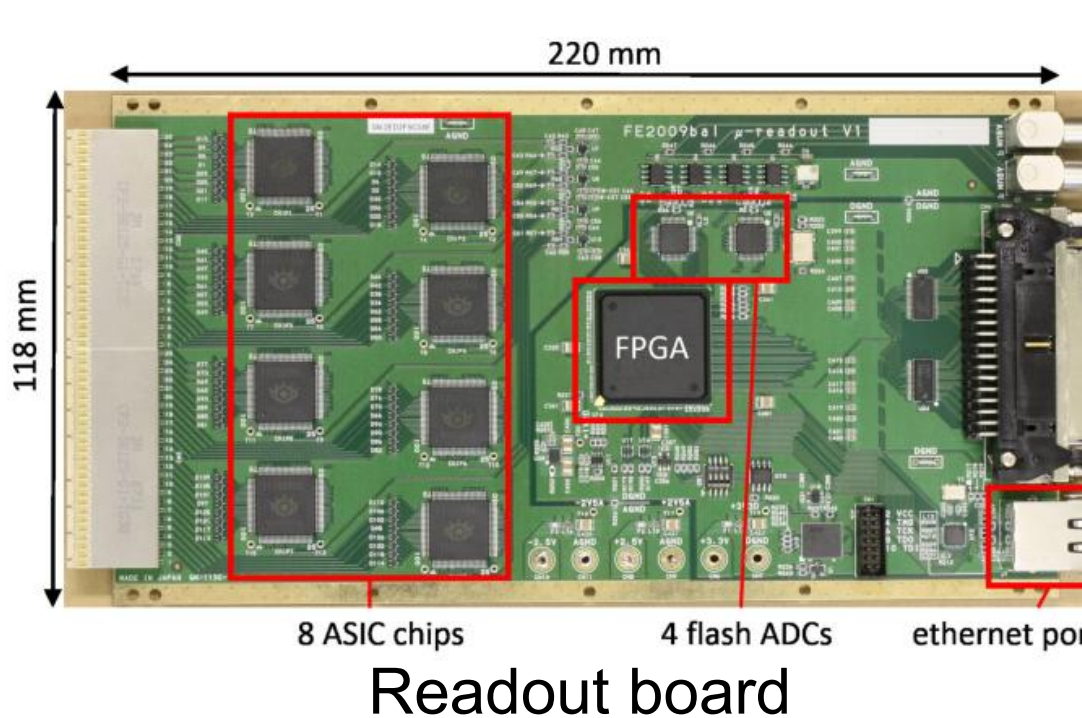

- Integrated DAQ system
 - Integrated control of 12 readout boards.
 - DAQ Controller as the core component for board management.

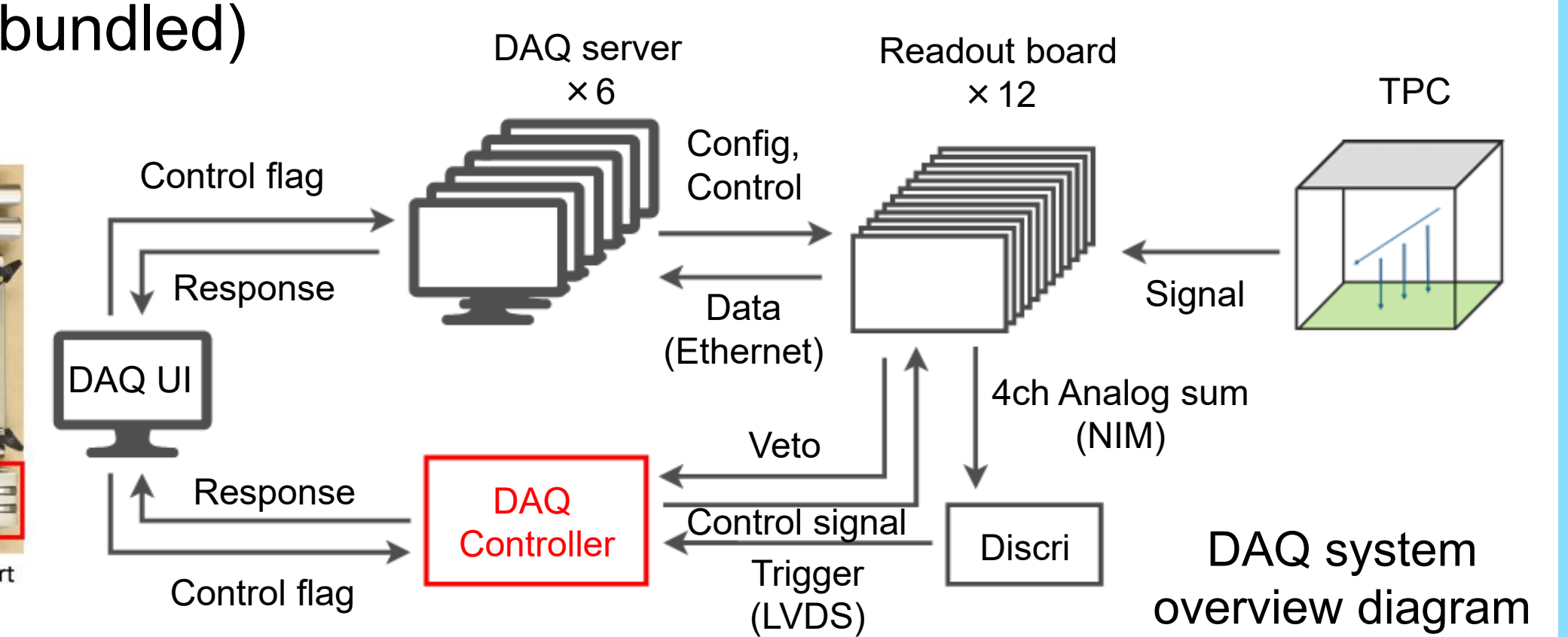

Development of DAQ Controller

Required Specifications

- Communication with DAQ UI
- Processing control signals
- Live time measurement
- Distributing control signals to each readout boards
- Realized by SoC + Mezzanine Card

DAQ Controller overview

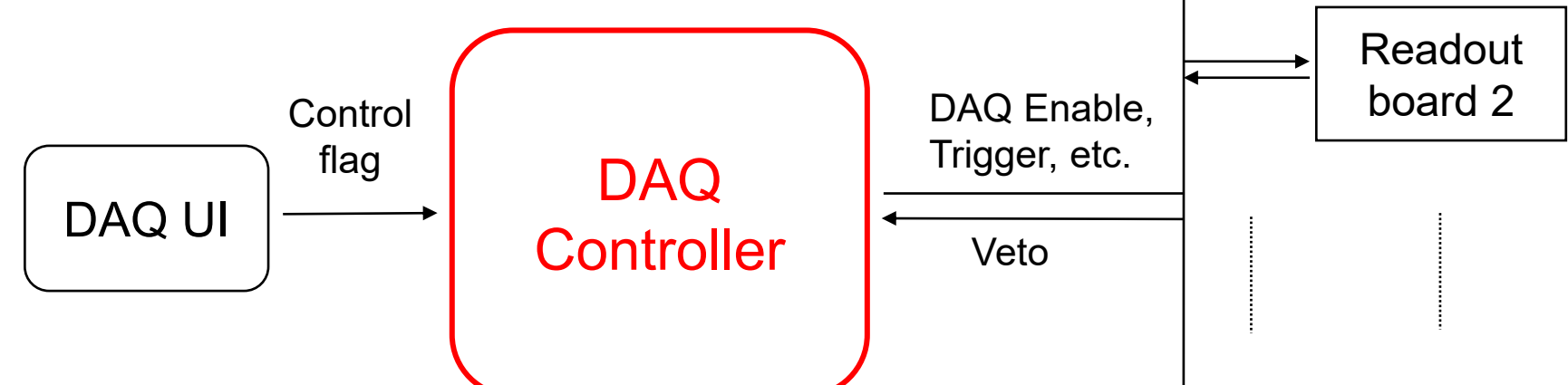

Mezzanine Card

- Custom-designed circuit board
- Signal interface between SoC and readout boards
 - Distribution of control signals from SoC to 12 boards
 - Signal conversion : LVDS \leftrightarrow Single-ended



Overview of DAQ Controller

SoC (System on Chip)

- Composed of Controller and Scaler parts
- Controller
 - Sends DAQ control signals to readout boards based on UI commands.
- Scaler part
 - Measurement real time and live time during operation.

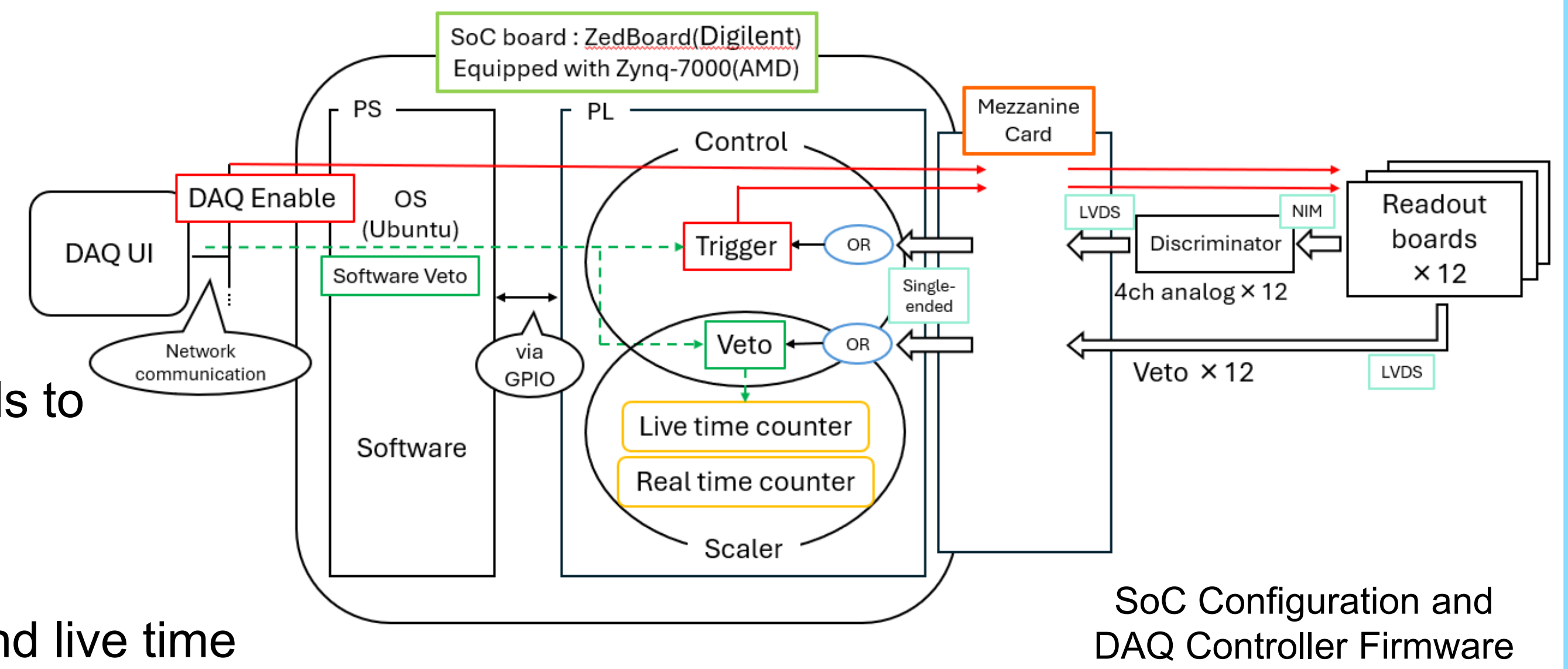

Performance Verification

- Standalone verification of DAQ Controller
 - Mezzanine Card : Verified signal distribution and their synchronization using test pulses.
- Integrated test with the detector.
 - Demonstrated data acquisition capability.
 - Confirmed synchronization between readout boards
 - Reconstructed long tracks crossing readout board boundaries.

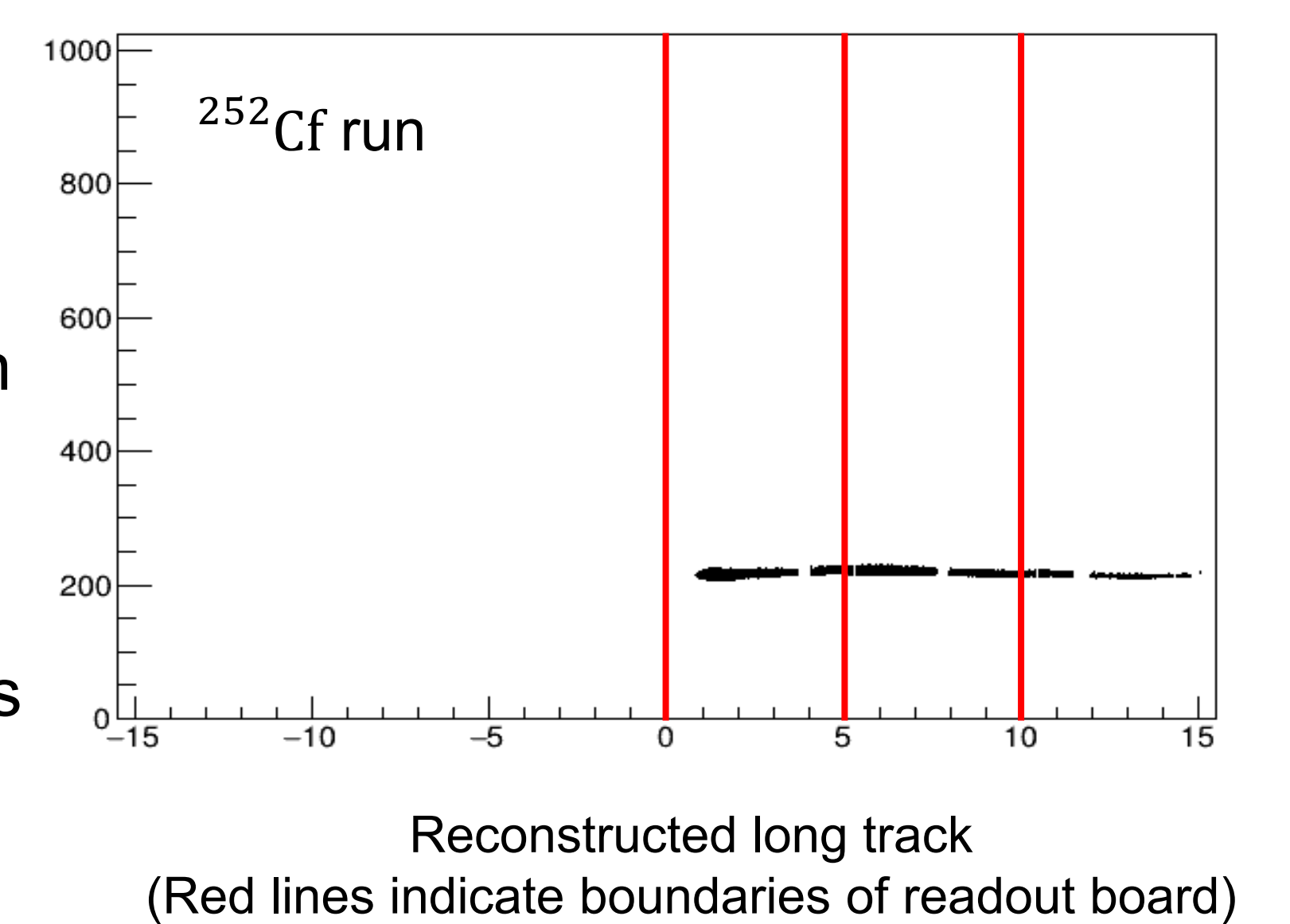

System Operation

System Operation in Neutron Beam Experiment

- Conducted a neutron beam test at AIST in November 2025.
- Operational results
 - Achieved stable system operation and successful data acquisition.
 - Detected both nuclear and electron recoil events.
 - Verified the functionality of the integrated 12-board readout system in a practical experimental environment.
 - Observed significant dead time.

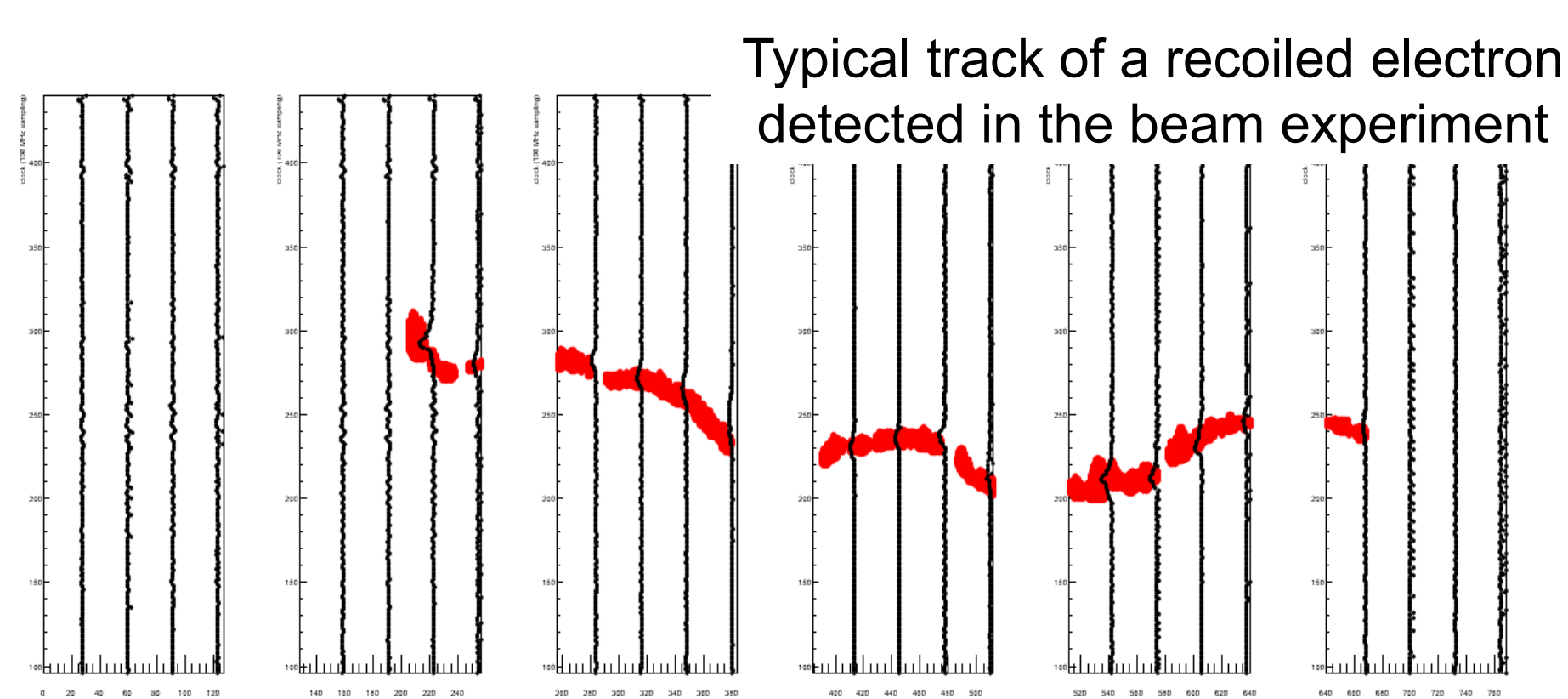
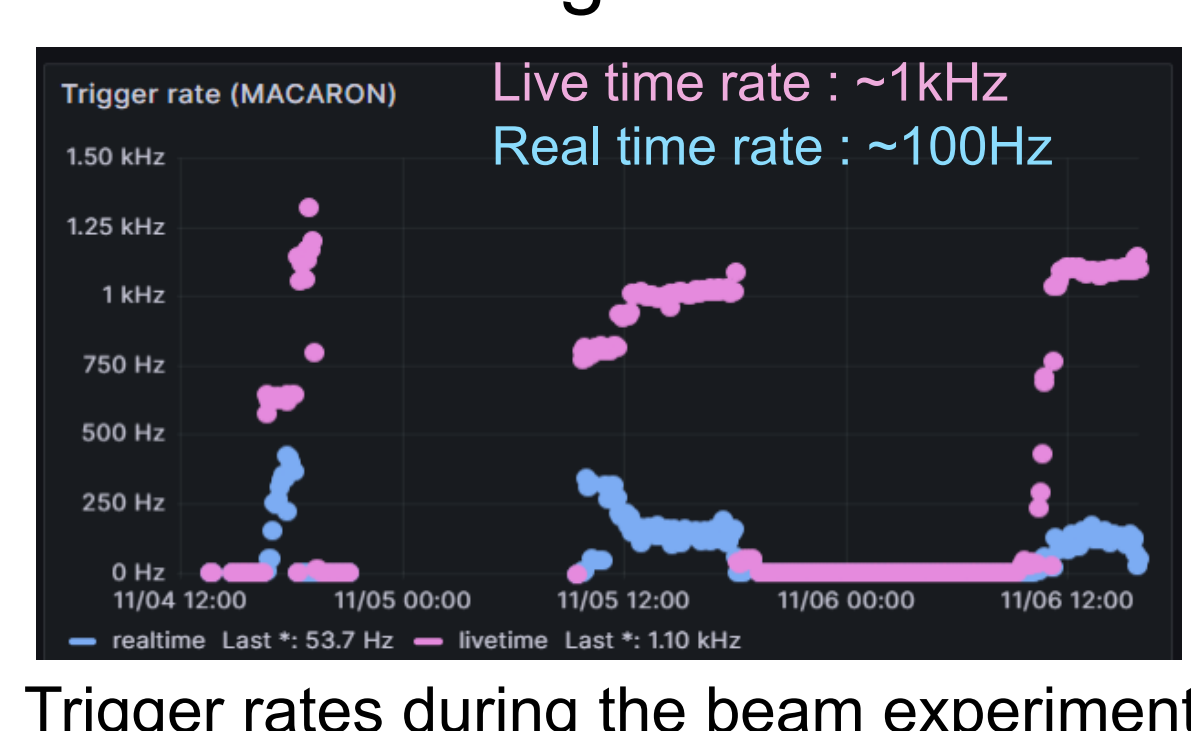

Outlook and Summary

Outlook

- Reviewing a comprehensive system to mitigate dead time further.
- Aim to observe the Migdal effect in Ar gas by advanced understanding of background events.
- This work also demonstrates the integration of the DAQ system into C/N-1.0.

Summary

- Developed an integrated DAQ system for a μ -PIC-based gaseous TPC.
- Operated the system during the beam experiment in November 2025.
 - Achieved data acquisition using a 12-board readout configuration.